

Gas/Liquid Separators

In-Line  
T-Type

Coalescers  
Two Stage  
Internal

Exhaust Heads  
Drain Traps

**Solving Your Need  
for Cleaner and  
Drier Air, Gas  
& Steam  
With Smarter  
Technology**

**EATON**

*Powering Business Worldwide*

Monarch Group - Filters, Strainers & Separators

Australia - [www.monarchindustrial.com.au](http://www.monarchindustrial.com.au)

Thailand - [www.psfthailand.com](http://www.psfthailand.com)

# Type TS Vertical Gas/Liquid Separators

1" to 24" Sizes • Threaded, Flanged or Socket Weld • Carbon Steel or Stainless Steel

Fabricated  
Construction  
Gas/Liquid  
Separator

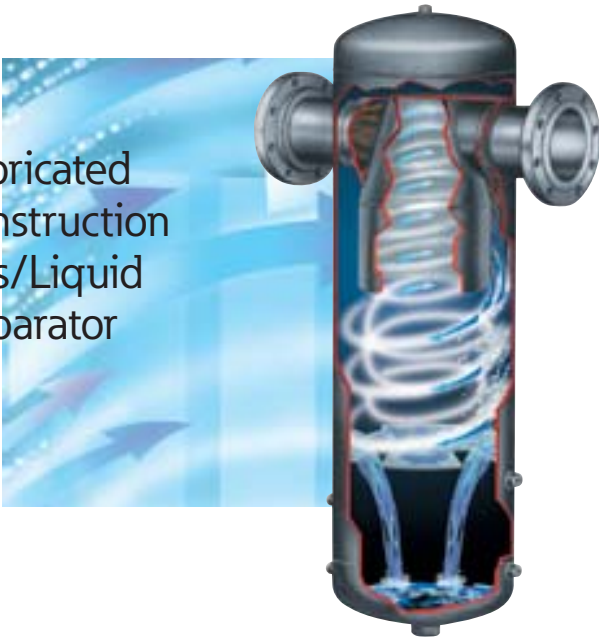

## FEATURES

- Designed for High Liquid Loading Applications
- High Efficiency Over Wide Flow Range
- No Required Maintenance
- Removes 99% of Liquid and Solid Entrainment Particles Larger Than 10 Micron
- Gas, Steam or Air Applications

## OPTIONS

- ASME UM or U Code Stamp (Carbon Steel and Stainless Steel Models)
- Support Legs

### High Efficiency – No Maintenance

The Eaton Type TS Gas/Liquid Separator automatically removes 99% of all liquid and solid entrainment particles 10 microns in size or larger from air, gas, and steam processes. And they do it with no moving parts to wear out and with no required maintenance.

### Applications

The Eaton Type TS gas/liquid separator is designed for applications where heavier than normal liquid loading causes a "slugging" problem. These applications are widely found in refineries and chemical plants. In many cases, there is a liquid holdup requirement where instrumentation is provided for controlling the level of the liquid in the reservoir of the vessel. Some common applications include upstream of gas turbines, absorption towers, steam generator outlets and gas scrubbers.

### Exclusive Design

Moisture laden gas enters the inlet of the separator where it is deflected in a centrifugal downward motion. The entrained solids and moisture droplets are separated out by a reduction in velocity. Separated liquid and solids fall into a reservoir where the exclusive Eaton Vortex Containment Plate (VCP) ensures that they can't be re-entrained. The clean, dry flow is then directed to the outlet by the Vortex Containment Plate. The VCP eliminates the need for expensive, delicate baffles used in ordinary separators.

### Fabricated Construction

The Type TS Separator is available in fabricated carbon steel, stainless steel or other alloy construction with socket weld, threaded and 150#, 300# and 600# flange

connections. Depending on the separator size liquid holdup capacities range from 0.19 cu. ft. to 32.64 cu. ft. or larger should the application require. The separators can be furnished with an ASME Code Stamp as an option. Optional, integral support legs can also be specified.

### Use Our Technical Support Services

Choosing the right gas/liquid separator can present unique problems not encountered in choosing other pipeline components. Especially when dealing with high liquid loading applications. Why not take advantage of our over 100 years of application experience with gas/liquid separators? Application specialists are available to help you every step of the way. From initial selection, to installation and through start-up... just contact us.

Monarch Group - Filters, Strainers & Separators

Australia - [www.monarchindustrial.com.au](http://www.monarchindustrial.com.au)

Thailand - [www.psftthailand.com](http://www.psftthailand.com)

## Typical Installation

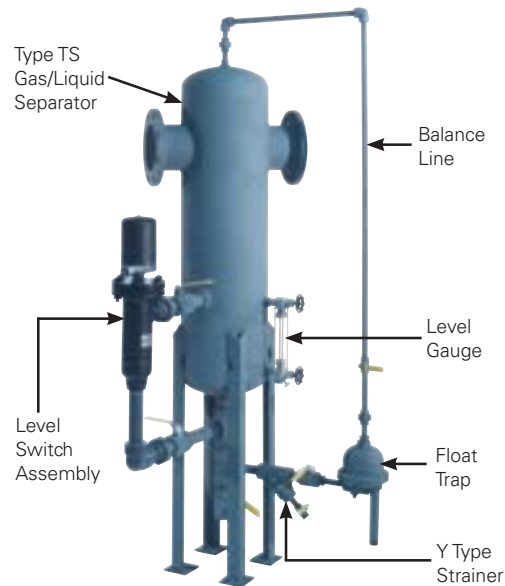
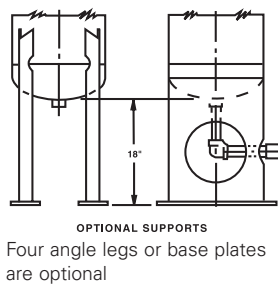
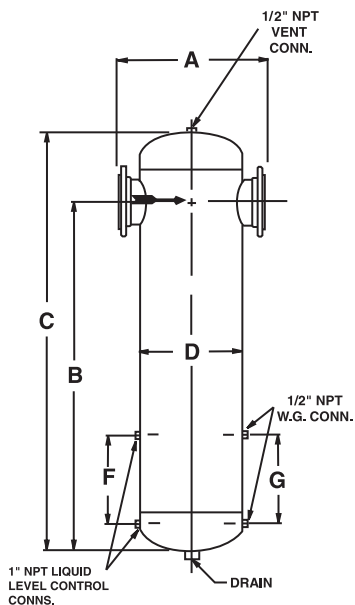

Dimensions – Type TS (Carbon Steel) with ANSI Flanges (in / mm)

Pipe Size	Threaded & Skt Weld A	Flanged A	B	C	D	F	G	NPT Drain Std	NPT Opt'l	Weight (lb/kg)			Liquid Holdup Cap. (cu ft/m)
										Thd'd & Socket Weld 1000 psig @ 650°F	150 lb Flanges 150 psig @ 450°F	300 lb Flanges 500 psig @ 650°F	
1	6.87 / 174	10.5 / 267	22 / 559	28 / 711	5.56 / 141	–	7.87 / 200	1	1-1/2	44 / 20	47 / 21	49 / 22	0.19 / 0.0053
1-1/4	6.87 / 174	10.5 / 291	22 / 559	28 / 711	5.56 / 141	–	7.87 / 200	1	1-1/2	45 / 20	50 / 23	52 / 24	0.19 / 0.0053
1-1/2	7.87 / 200	11.5 / 292	24 / 610	30 / 762	6.62 / 168	9.12 / 232	9.12 / 232	1	2	83 / 38	69 / 31	75 / 34	0.20 / 0.0056
2	7.87 / 200	11.5 / 292	24 / 610	30 / 762	6.62 / 168	9.12 / 232	9.12 / 232	1	2	85 / 39	74 / 34	78 / 36	0.20 / 0.0056
2-1/2	–	16 / 406	27 / 686	35 / 889	8.62 / 219	9.12 / 232	9.12 / 232	1	2	–	122 / 55	132 / 60	0.39 / 0.011
3	–	18 / 457	30 / 762	38 / 965	10.75 / 273	9.12 / 232	9.12 / 232	1-1/2	2-1/2	–	170 / 77	180 / 82	0.66 / 0.018
4	–	20 / 508	36 / 914	45 / 1143	12.75 / 324	10.25 / 260	10.25 / 260	1-1/2	2-1/2	–	225 / 102	250 / 114	1.07 / 0.03
5	–	22 / 559	40 / 1016	50 / 1270	14 / 356	10.25 / 260	10.25 / 260	1-1/2	2-1/2	–	265 / 120	335 / 152	1.35 / 0.04
6	–	24 / 610	55 / 1397	66 / 1676	16 / 406	10.25 / 260	10.25 / 260	1-1/2	2-1/2	–	400 / 182	435 / 198	3.03 / 0.084
8	–	28 / 711	62 / 1575	75 / 1905	18 / 457	11.87 / 301	11.87 / 301	2	3	–	545 / 248	700 / 318	3.83 / 0.107
10	–	34 / 864	76 / 1930	91 / 2311	24 / 610	11.87 / 301	11.87 / 301	2	3	–	800 / 364	1355 / 616	6.94 / 0.194
12	–	38 / 965	82 / 2083	99 / 2515	28 / 711	11.87 / 301	11.87 / 301	2-1/2	4*	–	1090 / 495	1735 / 789	11.74 / 0.33
14	–	42 / 1067	89 / 2261	108 / 2743	32 / 813	12.62 / 321	12.62 / 321	2-1/2	4*	–	1335 / 607	2535 / 1152	16.81 / 0.47
16	–	47 / 1194	98 / 2489	119 / 3023	36 / 914	12.62 / 321	12.62 / 321	3	5*	–	1850 / 841	3200 / 1455	20.22 / 0.57
18	–	54 / 1372	108 / 2743	132 / 3353	42 / 1067	12.62 / 321	12.62 / 321	3	5*	–	2600 / 1182	5025 / 2284	22.99 / 0.64
20	–	62 / 1575	118 / 2997	145 / 3683	48 / 1219	15 / 381	15 / 381	3	5*	–	3275 / 3275	6480 / 2945	26.47 / 0.74
22	–	64 / 1626	121 / 3073	149 / 3785	48 / 1219	15 / 381	15 / 381	3	5*	–	3450 / 1568	7000 / 3182	26.47 / 0.74
24	–	70 / 1778	127 / 3226	158 / 4013	54 / 1372	15 / 381	15 / 381	4*	6*	–	4940 / 2245	9020 / 4100	32.64 / 0.91

Note: Type TS separators are of welded steel construction in accordance with ASME code for unfired pressure vessels. Available in stainless steel on request. Inlet and outlet connections can be rotated radially, if specified.

\* Flanged drain

Monarch Group - Filters, Strainers & Separators  
 Australia - [www.monarchindustrial.com.au](http://www.monarchindustrial.com.au)  
 Thailand - [www.psfthailand.com](http://www.psfthailand.com)