

Gas/Liquid Separators

In-Line
T-Type

Coalescers
Two Stage
Internal

Exhaust Heads
Drain Traps

**Solving Your Need
for Cleaner and
Drier Air, Gas
& Steam
With Smarter
Technology**

EATON

Powering Business Worldwide

Monarch Group - Filters, Strainers & Separators

Australia - www.monarchindustrial.com.au

Thailand - www.psfthailand.com

DTL Dry type Gas/Liquid Separators

For Higher
Than Normal
Solids Loading



Type 33L-DTL

FEATURES

- Sizes from 2" to 16"
- For High Solid Loadings Applications
- Fabricated Carbon or Stainless Steel Construction
- Flanged Drain
- No Maintenance
- Low Pressure Drop

OPTIONS

- Larger Sizes
- Code Stamp



Type T-DTL



Type 31L-DTL

The Eaton Dry Type Gas/Liquid Separators have been designed for applications with a higher than normal load of entrained solids. In order to handle the large amount of solids, these separators feature a conical-shaped sump that better promotes the collection of removed solids at the drain port. The separated material collecting at the drain port must be removed before it fills the sump area. Since automatic drain traps are not suitable for draining solid materials, the use of a rotary valve is recommended for this purpose. This type of valve will allow the solid material to be removed while releasing a minimum amount of air, gas, or steam from the system.

When correctly specified and installed these separators will remove from an air, gas or steam stream 99% of all entrained liquid droplets and solid particles that are 10 microns in size or larger. The removed particles and liquid will accumulate at the drain port at the bottom of the drain sump for removal.

The Type DTL separators are centrifugal separators that cause the gas stream to enter a controlled centrifugal flow. This action forces the entrained liquids and solids to the outer wall. The exclusive Eaton Vortex Containment Plate (VCP) system shields these separated particles and liquid droplets from the vortex

action within the separator and directs them toward the drain sump. The exit stream is drawn from the clean and dry center of the separator. The VCP prevents re-entrainment of the removed liquids and solids and assures a clean and dry gas stream at the separator outlet.

Type DTL Separators are available in three different configurations. The DTL-T has a straight-through flow connection, the 33L-DTL has a vertical downflow inlet and a horizontal outlet, the 31L-DTL is a compact, straight-through flow design.

Monarch Group - Filters, Strainers & Separators
Australia - www.monarchindustrial.com.au
Thailand - www.psftthailand.com

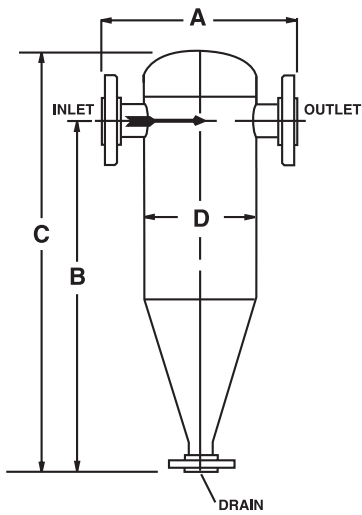

Type T-DTL

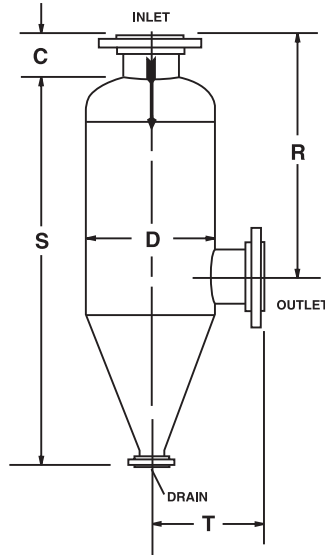

Type 33L-DTL

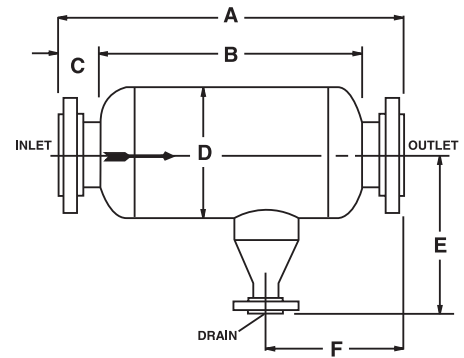

Type 31L-DTL

Dimensions – DTL Dry Type Gas/Liquid Separators (in/mm)

Pipe Size	A	B	C	D	Drain Flanged (NPT)
2	11.5 292	36 914	42 1067	6.62 168	2
2-1/2	16 406	37 940	43 1092	8.62 219	2
3	18 457	42 1067	50 1270	10.75 273	2 1/2
4	20 508	46 1168	55 1397	12.75 324	3
5	22 559	50 1270	60 1524	14 356	4
6	24 610	66 1676	77 1956	16 406	4
8	28 711	74 1880	87 2210	18 457	5
10	33 838	102 2591	117 2972	24 610	5
12	38 965	114 2896	131 3327	28 711	5
14	42 1068	118 2997	138 3505	32 813	8
16	47 1194	133 3378	154 3912	36 914	8

Pipe Size	C	D	R	S	T	Drain Flanged (NPT)
2	3 76	6.62 168	14 356	26 660	7 178	2
2 1/2	3 76	6.62 168	14 356	26.5 673	7 178	2
3	3 76	8.62 219	16 406	30 762	8 203	2-1/2
4	4 102	10.75 273	20 508	35 889	10 254	2-1/2
5	4 102	12.75 324	24 610	42 1067	11 279	3
6	4 102	14 356	27 686	52.5 1333	12 305	3
8	5 127	16 406	33 838	61 1549	13 330	4
10	5 127	20 508	40 1016	82 2083	15 381	4
12	5 127	24 610	46 1168	98 2489	17 432	5
14	5 127	28 711	52 1321	117 2972	19 483	8
16	5 127	30 762	59 1499	126 3200	20 508	8

Pipe Size	A	B	C	D	E	F	Drain Flanged (NPT)
2	22 559	16 406	3 76	6.62 168	16 406	11 279	2
2-1/2	22 559	16 406	3 76	6.62 168	16 406	11 279	2
3	24 5690	18 457	3 76	8.62 219	17 432	11 279	2-1/2
4	30 762	22 559	4 102	10.75 273	19 483	13.5 343	2-1/2
5	34 864	26 660	4 102	12.75 324	21 533	14 356	3
6	36 914	28 711	4 102	14 356	22 559	14 356	3
8	46 1168	36 914	5 127	16 406	23 584	19 483	4
10	52 1321	42 1067	5 127	20 508	26 660	20.5 521	4
12	60 1524	50 1270	5 127	24 610	29 737	23.5 597	5
14	66 1676	56 1422	5 127	28 711	35 889	25 635	8
16	74 1880	64 1626	5 127	30 762	44 1118	28 711	8

Monarch Group - Filters, Strainers & Separators
 Australia - www.monarchindustrial.com.au
 Thailand - www.psfthailand.com